

Tower Crane / Grue à tour / Gru a torre
Grúa torre / Guindaste de torre

Turmdrehkran 26 K

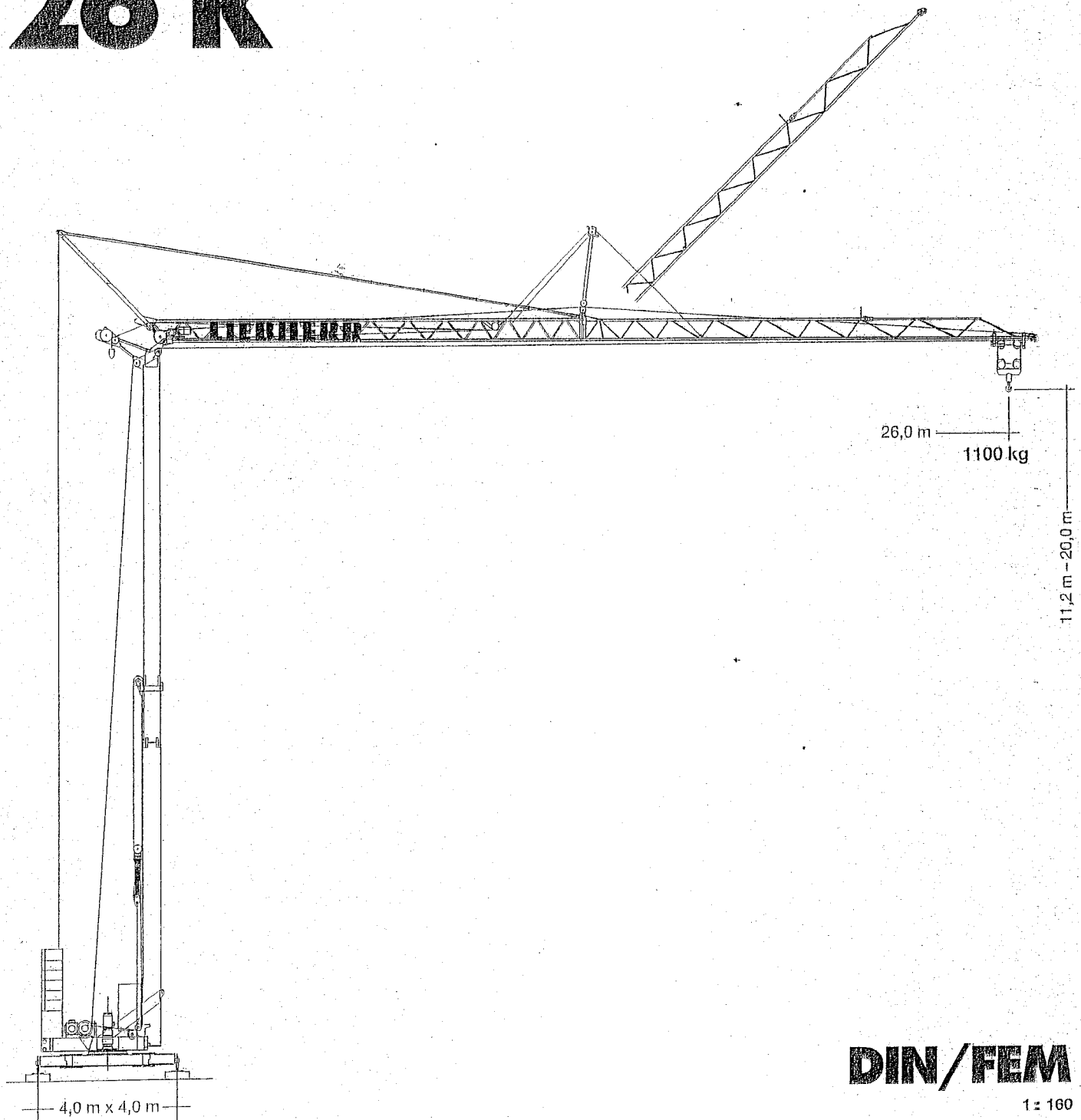

DIN/FEM

1:160

LEIBHERR

Gewicht

Weight / Poids / Peso / Peso / Pesos

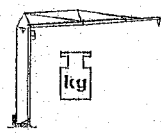
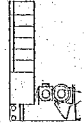
Zentralballast / Central ballast Lest de base / Zavorra centrale Lastro central / Lastre central	1080 kg		10000 kg
	r = 1,95 m	13000 kg	

Ausladung und Tragfähigkeit



Radius and capacity / Portée et charge / Sbraccio e portata / Alcances y cargas / Alcance e capacidade de carga

m	m/kg	m/kg																
		11,0	12,0	13,0	14,0	15,0	16,0	17,0	18,0	19,0	20,0	21,0	22,0	23,0	24,0	25,0	26,0	
26,0	2,5 - 12,4 2500	2500	2500	2370	2160	1985	1830	1700	1585	1480	1390	1310	1235	1170	1110	1100	1100	
22,0	2,5 - 12,9 2500	2500	2500	2480	2270	2080	1925	1790	1670	1560	1460	1400	1400					

Geschwindigkeiten

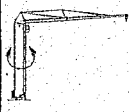
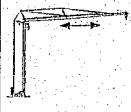
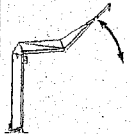
Speeds / Vitesses / Velocità / Velocidades / Velocidades

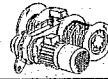
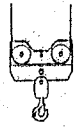
	U/min 0-0,8 sl./min tr./min	1,5 kW, EDC
	19,0 / 33,0 m/min	0,7 / 1,2 kW
	0-45° ca. 38 sec.	2,2 kW

	Stufe / Step / Cran Marcha / Velocidad Velocidade	kg		m/min	
11,0 kW (KL)		1	2500	5,0	
		2	2500	20,0	
		3	1300	40,0	
11,0 kW (FU)		1	2500	5,0	
		2	2500	20,0	
		3	1800	30,0	
		4	1300	40,0	

BGL:  2105-0028

	400 V	Hz	kVA
28,0 m	4 x 6 mm ² (KL) 4 x 6 mm ² (FU)	50	21,0 (KL) 17,0 (FU)

Technische Daten

Technical data - Caractéristiques techniques

Aufstellvorgang

Erection procedure

Déroulement de montage

Procedimento di montaggio

Procedimiento de montaje

Sistema de montagem

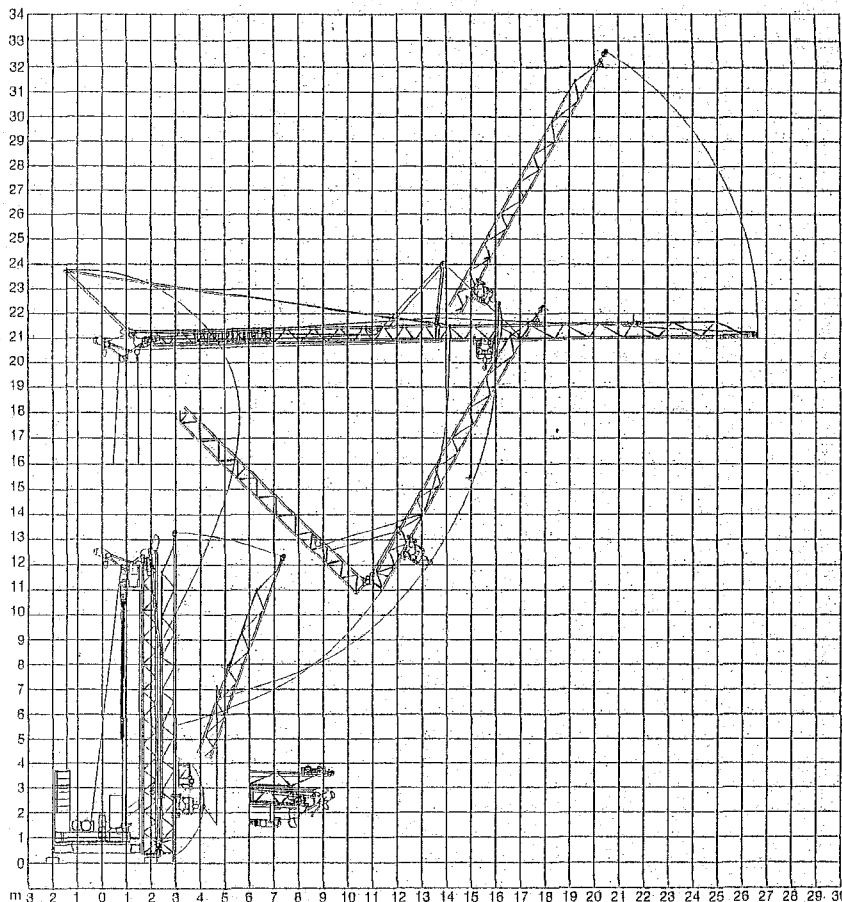

Kolli-Liste

Packing List / Liste de colisage / Lista dei colli

Lista de contenido / Lista de embalagem

Pos. / Anz.	Item Qty.	Rep. Qte.	Voce Qta.	Pos. Cant.	Ref. Cant.		L (m)	B (m)	H (m)	kg	
1	1*					Transportachse vorne Tra 100 KY 2 Road transport axle front / Essieux de transport avant / Asse di trasporto anteriore / Eje delantero para transporte / Elxo de transporte dianteiro		3,00	1,13	0,97	660
2	1					Transportachse hinten Tra 120 GY 1A Road transport axle behind / Essieux de transport arrière / Asse di trasporto posteriore / Eje trasero para transporte / Elxo de transporte traseiro		1,90	2,50	1,05	1150
3	1					Kiste mit Seilen und Kleinteilen / Case with ropes and small parts Caisse avec câbles et pièces détachées / Cassa con funi e accessori Caja con cables y piezas sueltas / Caixa contendo cabos e acessórios		1,00	0,80	1,00	450

120 P - 4028 H1 B3 DIN 15018 / FEM (Section 1) Krangruppe A3 und OENORM T3 • 01.99 / 6

Konstruktionsänderungen vorbehalten! / Subject to alterations!
 Sous réserves de modifications! / Si fa riserva di modifiche!
 Salvo modificação da construação! / Sujeto a modificaciones!

Printed in Germany.